

## **Masport R1200 Pedestal & Leg – Technical Specifications**

(These instructions must be used in conjunction with the “General Installation Instructions” for Masport Fires)

**R1200 burner models have been tested and complies to following standards & tests:**  
**NZ National Environmental Test Standards - AS/NZS 4012:2014 and AS/NZS 4013:2014.**  
**NZ National Environmental Safety Test Standard - AS/NZS 2918:2001**

<b>Overall Dimensions</b>	493mm Wide x 510mm Deep x 640mm High		
<b>Weight</b>	105 kg		
<b>Test Method</b>	<b>Emissions mg/MJ</b>	<b>Emissions g/kg</b>	<b>Efficiency %</b>
<b>National Environment Standard AS/NZS 4012/13:2014</b>	36.4 mg/MJ	0.49 g/kg	65.8%
<b>ECan Authorization Number :</b>	Pedestal – CRC191120 ; Leg – CRC191121		
<b>Approx. Heating Capacity</b>	Small Homes		
<b>Flue Shield</b>	900mm Long SS Masport Double Flue Shield		
<b>Flue System</b>	Std 4.2M Long, 150mm Masport Flue System or Flue System that has been tested to and comply with AS/NZS 2918:2001 Appendix F.		
<b>Floor Protector Requirement</b>	Ash Floor Protector		

### **Minimum Clearances to Combustibles:**

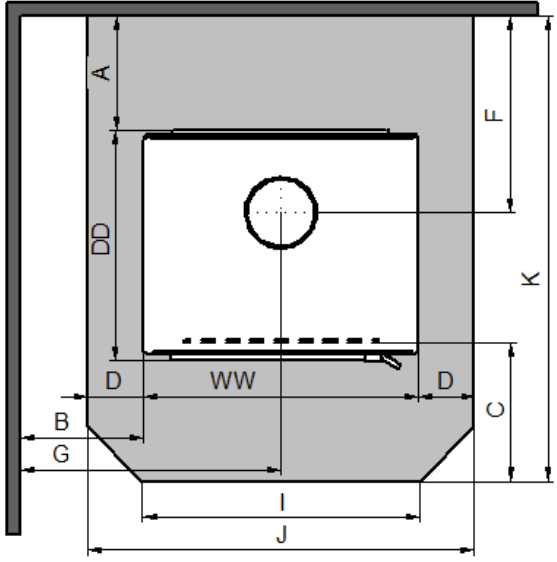
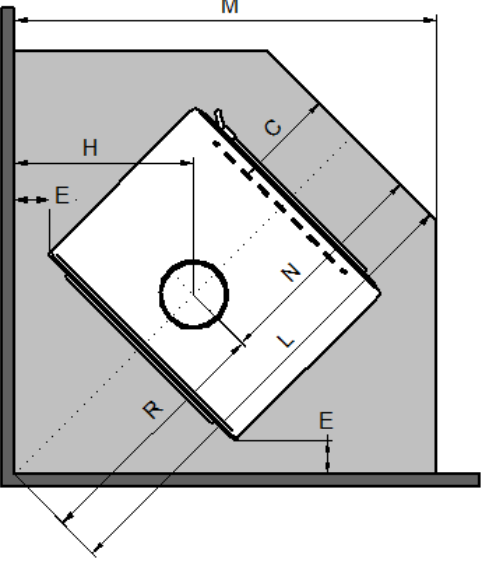
<b>Parallel Installation</b>		<b>Corner Installation</b>	
			
A- Rear Panel to Rear Wall	100 mm	C- Glass to Floor Protector Front	300 mm
B-Cooktop Edge to Side Wall	280 mm	E- Cooktop Corner to Wall	100 mm
C- Glass to Floor Protector Front	300 mm	H- Flue Centre to Wall	401 mm
D- Floor Protector Side	116 mm	<b>L- Floor Protector Diagonal</b>	<b>1165 mm</b>
F- Flue Centre to Rear Wall	290 mm	<b>M- Floor Protector Side</b>	<b>974 mm</b>
G- Flue Centre to Side Wall	527 mm	N- Flue Centre to Floor Protector Front	598 mm
I- Floor Protector Front Edge	425 mm	R- Flue Centre to Wall Corner	567 mm
<b>J- Floor Protector Width</b>	<b>725 mm</b>	WW- Overall Width of Fire	493 mm
<b>K- Floor Protector Depth</b>	<b>888 mm</b>	DD- Overall Depth of Fire	510 mm
		HH- Overall Height of Fire	640 mm

**Seismic Restraint** - In New Zealand and some part of Australia, it is required that the wood burner and floor protector are secured to prevent shifting in the event of an earthquake. This is best done by fastening the wood burner right through the protector to the floor, using 8mm DynaBolts or 8mm coach screws or equivalent toggle fasteners for wooden floors of appropriate lengths. Seismic holes are at the rear of the burner.

# FLUE SYSTEM INSTALLATION

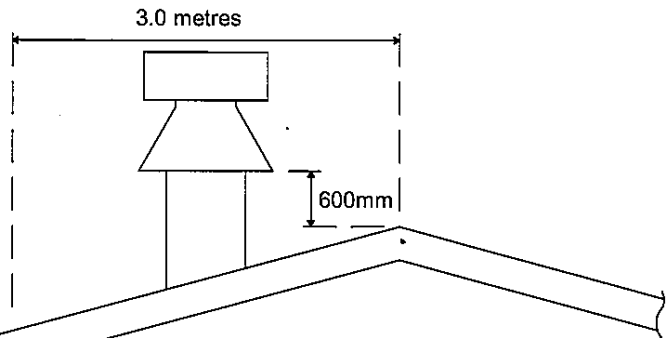
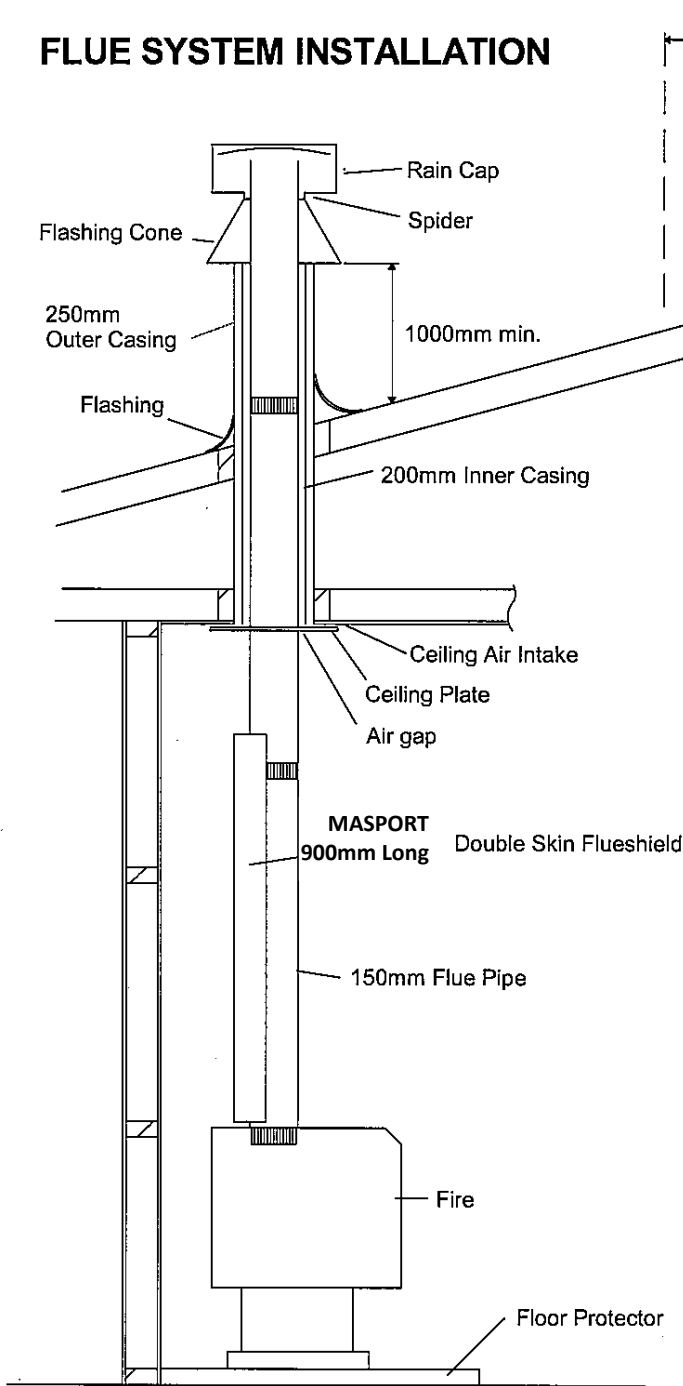

Installation shown complies with AS/NZS 2918:2001. If a flue exits out of the roof within 3 metres from the ridge, the outer shield height shall be not less than 600mm above the ridge. If the flue exits further than 3 metres out from the roof ridge then it must project at least 1000mm above roof penetration. This dimension may need increasing to ensure that the top of the flue is at least 3 metres away from the roof or other obstructions when measured horizontally.

The flue pipe shall extend not less than 4.6m above the top of the floor protector. Due to factors such as roof pitch, predominant winds, nearby obstructions (ie. trees, buildings), and fire placement, flue lengths and hats/cowls may vary.

## CEILING PENETRATION PLAN

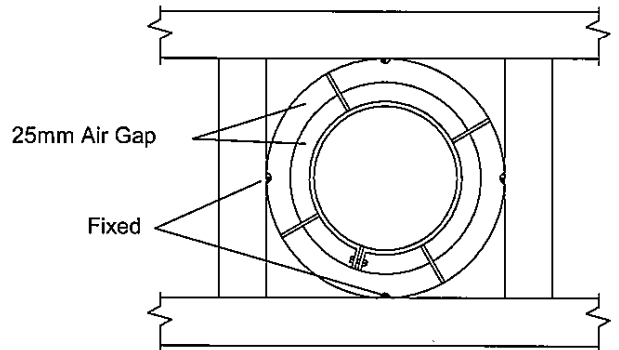

Above plan is valid only for flue manufactured by Glen Dimplex New Zealand Ltd

For other products, use specific flue installation specifications supplied by the manufacturer.

FLUE SYSTEM INSTALLATION 150mm